

**ADVANCED
POWER
TECHNOLOGY®**

APT9805

By: Kenneth Dierberger

APPLICATION NOTE

**Performance Comparison of the New Generation of IGBTs
with MOSFETs at 150kHz**

**Presented at Powersystems 98
Santa Clara**

Performance Comparison of the New Generation of IGBTs with MOSFETs at 150kHz

Ken Dierberger
Advanced Power Technology Inc.
405 SW Columbia St.
Bend, OR 97702 USA

ABSTRACT

In today's power electronic market place, as in other areas of electronics, reducing cost is necessary to stay competitive. To meet this need a new generation of IGBT is now offering near MOSFET switching speed with the promise of 150kHz hard-switched operation.

This paper will present data collected from the operation of these new IGBTs in a hard-switched double-ended feed forward converter switching at 150kHz. Their operation will be compared to a similarly rated MOSFET in the same circuit.

INTRODUCTION:

It has been assumed that the reader has a basic understanding of the theory of operation of both the power MOSFET and the IGBT.

IGBTs have been historically manufactured using two different technologies. In the past, the most widely used technology has been Punch Through (PT). The PT process relies on the use of a heavily doped P+ substrate with an N- epi grown on the surface. A MOSFET structure is then fabricated on the epi surface to form the IGBT, Figure 1. In contrast the Non-Punch Through (NPT) process relies on the use of a

lightly doped homogeneous N- substrate, no epi, and a MOSFET structure fabricated on the surface, Figure 2. The Emitter-Base PN junction, required on the back of the wafer, is formed using a light P+ implant and a shallow diffusion.

Both technologies require a relatively thick 400 μ m wafer to withstand the stresses of high temperature processing to form the MOSFET structure. During conduction both technologies rely on the injection of minority carrier holes into the N- drift region to reduce voltage drop across the N- drift region. To minimize the ON voltage PT technology uses an epi thickness that is the minimum required to support the rated break

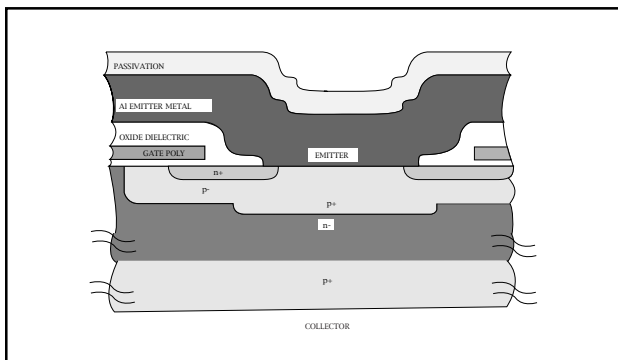

Figure 1. Punch Through IGBT cross-section (not to scale).

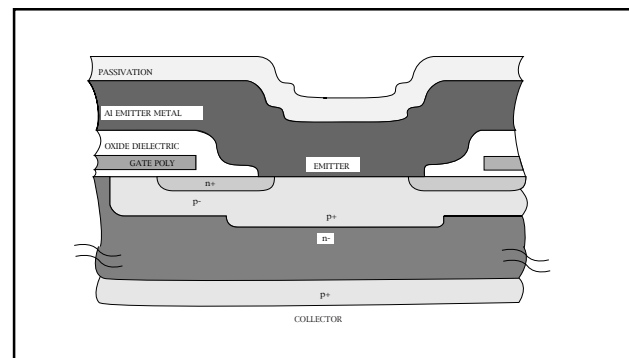

Figure 2. Non-Punch Through IGBT cross-section (not to scale).

down voltage, $80\mu\text{m}$ for a 600V IGBT, on the heavily doped P+ substrate. The thickness of the epi along with the high injection efficiency of the P+ substrate keeps the voltage drop across the epi low. The heavy doping of the substrate keeps the voltage drop low across the substrate in spite of its thickness. Also an N+ buffer layer must be added between the N- epi and the P+ substrate to minimize minority carrier hole injection. This improves switching speed and lessens the chance of latch-up. It does add to the cost of the epi. On the other hand, NPT technology thins the wafer to reduce the thickness of the N- drift region. The desired $80\mu\text{m}$ thickness is not yet achievable with today's thinning technology but an acceptable thickness of $100\mu\text{m}$ is achievable. The thickness of the wafer along with minority carrier injection from the implanted P+ emitter keeps the voltage low across the drift region. The lightly doped backside P+ region has a thickness of only a few μm keeping the voltage drop low across this region. The N+ buffer is not needed between the N- drift region and the P+ emitter to improve switching speed or to prevent latch-up. The minority carrier injection is controlled by limiting the amount of the P implant on the backside of the wafer. Figure 3 compares the relative thickness of NPT and PT technologies.

As a direct result of the lightly doped P+ emitter, high-speed turn-off is inherent in the NPT technology. Therefore, the added cost of minority carrier lifetime control processing is not required with NPT technology. The doping of the P+ emitter region is precisely controlled to make the injection efficiency just enough to provide a low $V_{ce(on)}$. This is in contrast with the PT IGBT where the heavily doped P+ substrate, which is required for low voltage drop across the substrate, results in a very high injection efficiency. This generates an excess of minority carriers that must be removed at turn-off to prevent slow turn-off speed. Both technologies produce very high speed IGBTs but the turn-off speed of the PT IGBT is temperature dependent and slows as temperature is increased. The turn-off speed of the NPT IGBT is only slightly temperature dependent and

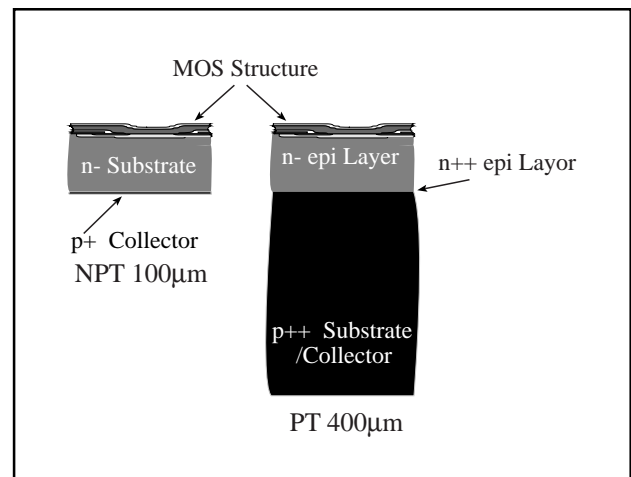

Figure 3. 100 μm thick NPT IGBT compared with a 400 μm thick PT IGBT (scaled).

remains relatively constant over the operating temperature range. Figure 4 and Figure 5 compare the turn-off speed and energy loss, at a junction temperature of 150°C , of a new NPT IGBT from Advanced Power Technology with a similarly rated, latest generation PT IGBT from a competitor. Both of these devices have comparable turn-off collector current fall times of 60nsec at 25°C . However, at 150°C the NPT device fall time remains about 60nsec, with a turn-off energy loss of about $45\mu\text{J}$ where the PT device is now well over 100nsec with a turn-off energy loss of about $76\mu\text{J}$.

PERFORMANCE COMPARISON AT 150kHz:

The bottom line as to the proof of whether or not any technology or device is acceptable to replace another is to actually operate the different devices and technologies in a circuit and compare how they perform. To accomplish this a 200Watt double-ended feed forward converter was constructed. Figure 6 is the schematic of the power conversion section of the converter. A pair of IGBTs from three manufactures, who claim their devices are capable of 150kHz operation, were tested along with a MOSFET from one manufacturer. The IGBTs were similarly rated for 6 to 7Amps at 90 to 110°C case temperature and have chip areas of 9.2mm^2 , 7.3mm^2 and

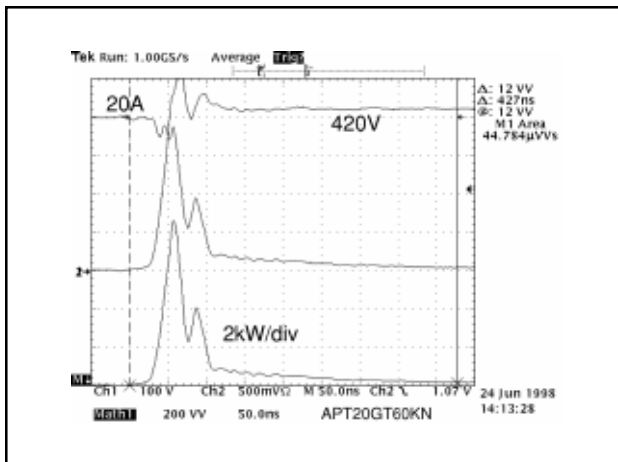

Figure 4. NPT IGBT turn-off at 150°C.

unknown mm². The MOSFET was rated for 8Amps at 25°C case temperature and has a chip area of 24.9mm².

The circuit was operated with 385Vdc input and an output of 15Vdc. The load was varied from 30 to 200W. The devices were attached to a 1" X 2" heat sink and cooled by a fan such that the case temperature of the devices were held at 100°C at full load. The MOSFETs did not require fan cooling as their case temperature did not reach 100°C at full load but stabilized at 85°C with no fan cooling.

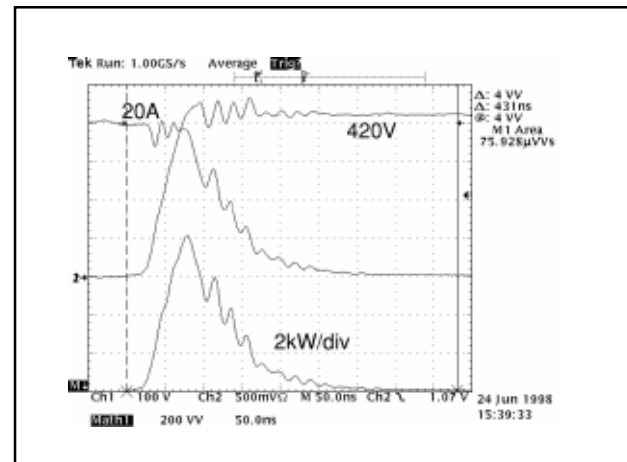

Figure 5. PT IGBT turn-off at 150°C.

The MOSFET pair performed best in terms of overall efficiency. The efficiency remained at 85±1% over the 100 to 200W load range and did not require fan cooling. One pair of PT IGBTs became thermally unstable and ran away. The devices could not be stabilized and eventually failed. This manufactures devices are not included in the performance graph, Figure 7. The second pair of PT IGBTs had an efficiency of about 84% at the 100W load and dropped of to just over 80% at the 200W load. The NPT pair of IGBTs started at 80% efficiency at the 100W load and the

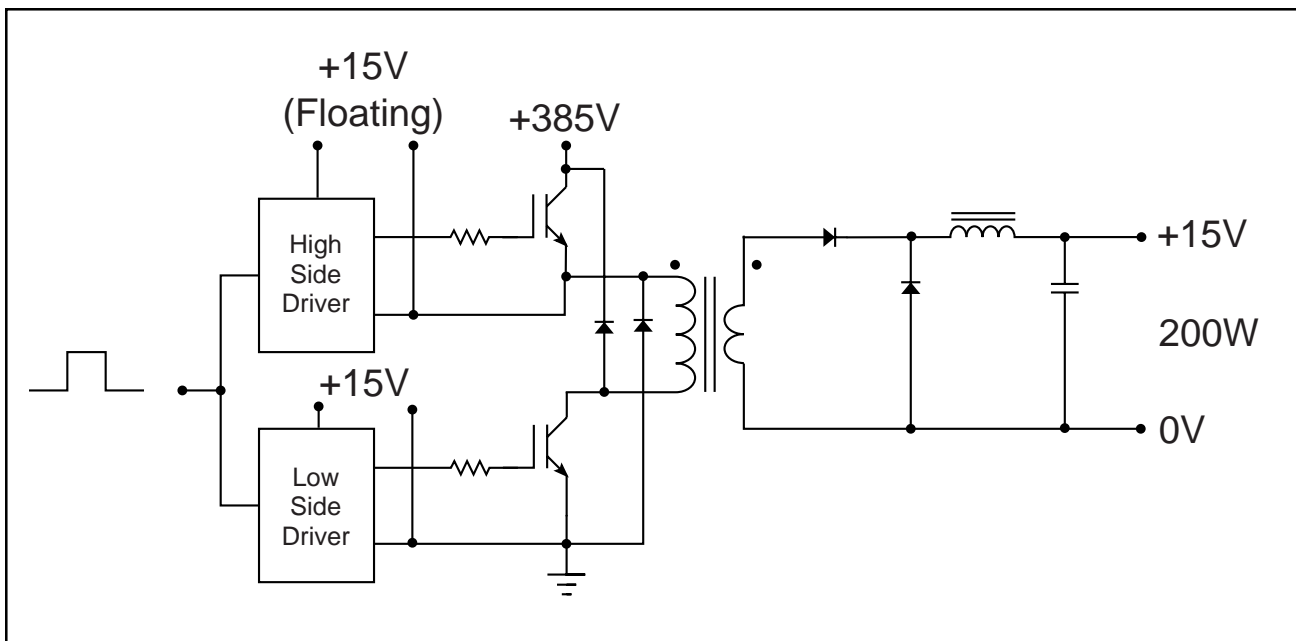

Figure 6. Schematic of the power section of the converter.

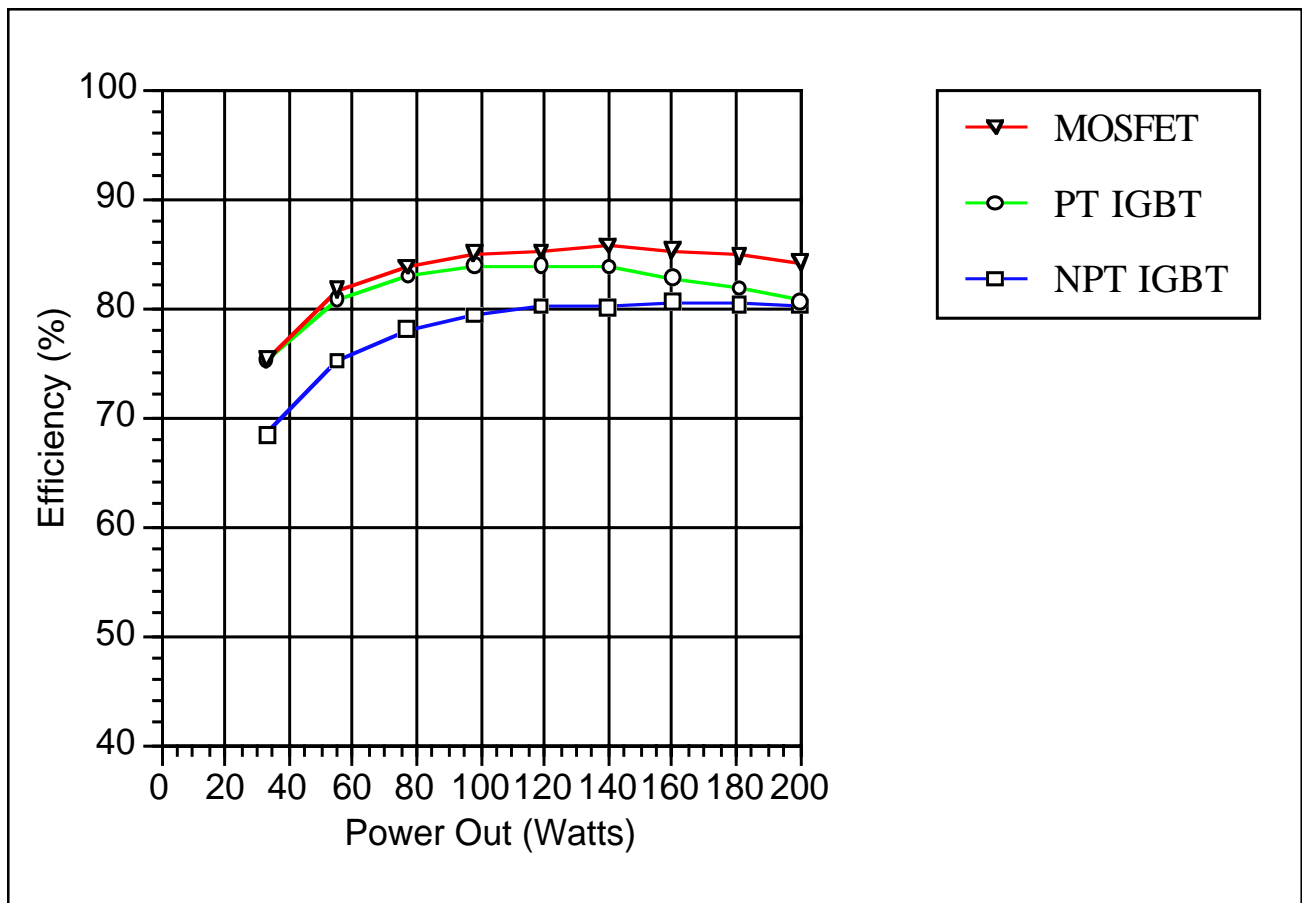

Figure 7. Performance efficiency versus Power Out.

efficiency remained flat at 80% all the way to the 200W load. A graph of the efficiency versus Power Out of the NPT, PT IGBTs and the MOSFETs over the load range is shown in Figure 7.

CAN THE IGBT REPLACE THE MOSFET:

The MOSFET is still king of the mountain if efficiency is the only criteria used to determine the winner. However, if cost is a consideration and the IGBTs works in the application, the IGBT becomes a viable candidate. The IGBTs evaluated in this paper were 2 die sizes smaller than the MOSFETs tested. The PT IGBT was less than 1/2 the area of the MOSFET and the NPT IGBT was less than 1/3 the area of the MOSFET. As device pricing is heavily dependent on the area of the chip, this would indicate the IGBT should be the lower cost device. The IGBT should have the price advantage. The NPT IGBT is 25%

smaller, has a lower material and processing cost than the PT IGBT. Therefore, it should also have a cost advantage over both the MOSFET and the PT IGBT. Other considerations are the NPT IGBTs used have an avalanche energy rating specified on the data sheet, as well as a square Turn-off SOA, like the MOSFET, where the PT IGBT does not. The NPT IGBT has a 10 μ sec short circuit capability where neither the PT IGBT nor the MOSFET offers this capability.

CONCLUSIONS:

Depending on the priorities of the design the IGBT has been shown a viable candidate for power applications with operating frequencies up to 150kHz. If cost is a major consideration, the IGBT should be the device of choice. The decision is yours.



ADVANCED POWER TECHNOLOGY[®]

405 S.W. Columbia Street
Bend, Oregon 97702 USA
Phone: (541) 382-8028
Fax: (541) 388-0364
<http://www.advancedpower.com>

Parc Cadera Nord - Av. Kennedy BAT B4
33700 Merignac, France
Phone: 33-557 92 15 15
Fax: 33-556 47 97 61